

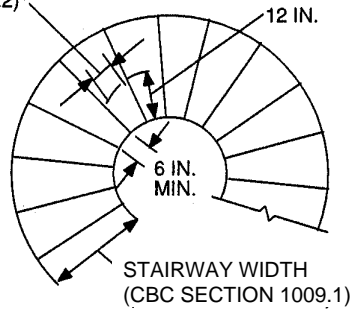

## BUILDING DEPARTMENT INFORMATIONAL HANDOUT #9

### Stairways (California Building Code Section 1009.3)

REQUIRED WIDTH OF RUN SHALL BE PROVIDED IN THIS LOCATION (SECTION 1003.3.3.8.2)



REQUIRED WIDTH OF RUN SHALL BE PROVIDED IN THIS LOCATION (SECTION 1003.3.3.8.2)

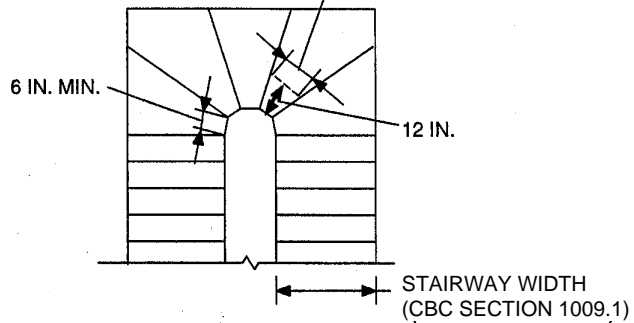

LIMITATION: APPLIES TO R-3 OCCUPANCY AND PRIVATE STAIRWAYS IN R-1 OCCUPANCY.

PLAN VIEW  
WINDING STAIRWAY

PLAN VIEW  
ALTERNATE USE OF WINDERS

THE LARGEST RISER HEIGHT WITHIN ANY FLIGHT OF STAIRS SHALL NOT EXCEED THE SMALLEST BY MORE THAN  $\frac{3}{8}$  IN. (SECTION 1003.3.3.3)

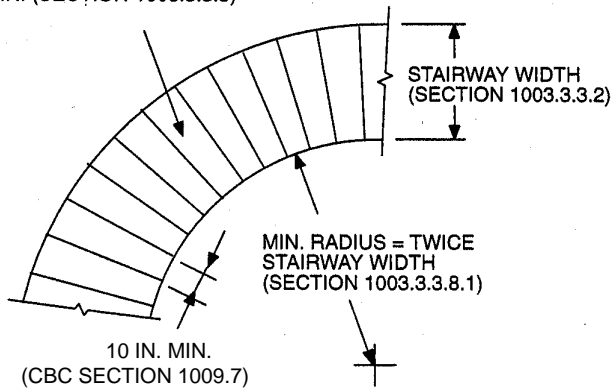

PLAN VIEW  
CIRCULAR STAIRWAY

MAX.  $9\frac{1}{2}$  IN. RISE BETWEEN TREADS

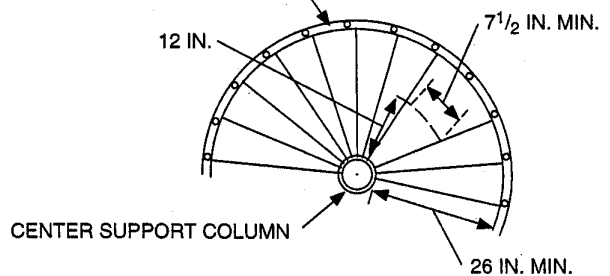

LIMITATIONS:

1. ONLY APPLIES TO R-3 OCCUPANCY AND PRIVATE STAIRWAYS IN R-1 OCCUPANCIES.
2. LIMITED TO SERVING AS EXIT FOR 400 SQUARE FEET MAXIMUM.

PLAN VIEW  
SPIRAL STAIRWAY

**NOTE:** Handrails not shown for clarity.

For SI: 1 inch = 25.4 mm, 1 square foot = 0.0929 m<sup>2</sup>.